

When using a floor plate, the safety distances stipulated by DIN 18891 apply.

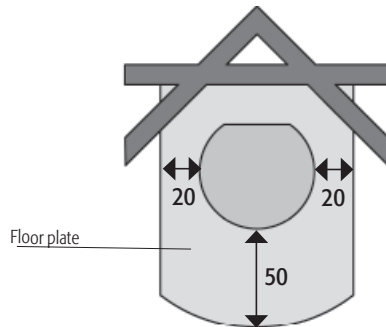

Fig. 2

Distances to Heat-sensitive and Combustible Materials

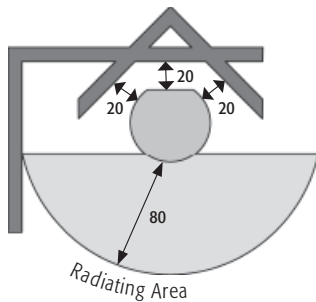

Fig. 3

3. Installation

Check to make sure that the load-bearing capacity of the floor / installation surface is sufficient. If necessary, using a floor plate to distribute the load can increase the load-bearing capacity.

In addition, check whether the room in which the Granada / Kyoto is to be installed is sufficiently supplied with fresh air. If the windows and doors are tightly sealed, the necessary supply of fresh air may not be ensured, which can interfere with the draught capability of the stove and chimney. If additional combustion air inlet openings are required, they are not permitted to be closed or obstructed.

Simultaneous operation of the stove and the exhaust hood can cause negative pressure to build up in the room where the stove is installed, which can lead to problems such as flue gas escaping from the stove.

To ensure that air is not drawn out of the room where the stove is installed, we recommend locking exhaust hoods that guide the air to the outside by means of a window contact switch.

4. The Chimney

The Granada / Kyoto has to be connected to a suitable chimney with a minimum effective chimney height of 4.50 m. With the design 1 reduction panel it can be connected to a chimney to which other fireplaces are already connected. The chimney cross section should correspond to the flue pipe cross section. If the effective chimney height is too low and/or the chimney cross section is too large or too small, the draught capability of your stove can be impaired.

The Granada / Kyoto stove requires a 12 Pa output pressure (chimney draft). At higher output pressures, the stove emissions increase, which puts a high load on the stove and can lead to damage. The Granada / Kyoto stove has a maximum permissible output pressure of 35 Pa.

To limit the output pressure, a butterfly valve or output pressure limiter can be used.

The **Granada** stove, certified in compliance with **DIN-EN 13240 : 2001 + A2 2004 and Art. 15 a B-VG (Austria)**, can only be operated when the fire box is closed; more than one device can be connected to the chimney, if the reduction panel was installed..

VKF No.: 11670; **Inspection Report No. (A):** RB BF-1Hn 1029

The following data applies to the chimney characteristics in accordance with EN 13384-1 / -2:

Combustion Values	Wood	
Nominal Thermal Output	9	kW
Waste Gas Mass Flow Rate	10	g/s
Waste Gas Outlet Temp.	270	°C
Min. Supply Pressure at Nominal Thermal Output	11	Pa
CO content at 13% O ₂	1488	mg/m ³
Efficiency	78	%
Particulate	35	mg/m ³

Depending on the insulation of the building, the nominal thermal output of **9 kW** indicated on the unit's type plate is sufficient for **35 - 130 m²** (subject to change).

Dimensions:

	Height	Width	Depth
Stove	153,5 cm	57 cm	52,5 cm
Fire Box	62 cm	28 cm	30 cm

Weight 249 kg

Connection Dimensions:

Connection height	143 cm
Connection height back, pipe centre	133,5 cm
Distance from back wall of stove to flue pipe centre	14,5 cm
Connection height Combustion air inlet, pipe centre*	13 cm

Fire Box Opening	630 cm ²
Flue Pipe Diameter	150 mm
Flue Pipe Diameter Hase-Combustion air inlet*	100 mm

Connection branch top (rear installation possible.)

*For separate air supply in low-energy houses and insufficient combustion air supply in the room where the stove is installed

